



Deep fryer
Linie
2000Vario

The All-In deep fryer for
excellent results



THE 2000 LINE IN THE VARIO DOUBLE STATION ALLOWS YOU TO WORK EFFICIENTLY AT THE HIGHEST LEVEL. WITH THE INNOVATIVE TOUCH PANEL CONTROL, YOU CONTROL THE ENTIRE MACHINE FULLY AUTOMATICALLY BY PUSHING THE BUTTON.

BENEFIT

- efficient working with 2 devices and common table in the middle
- tightly closing WP RIEHLE volume cover for bigger volume on the weighed-in quantity
- longer fat life by pulsed heating during heating up the fryer
- minimum energy consumption and constant temperature due to heating coils in the oil
- lowest fat absorption due to constant temperature
- computer control with 10 individually programmable baking programs for consistent quality
- automatic mode creates free working time during the baking process



TOUCH-CONTROL

- insensitive to grease and dirt
- the computer control is operated via the touch panel.
- 20 individually programmable baking programs can be stored
- the software is extremely user-friendly and intuitive operable
- benefit by the outstanding automatic mode!



OPTIONS

- fermentation chamber, closed to bottom with integrated 2-liter water tank, separately or built-in available (in combination with oil drain tank only separately available)
- optional oil drain tank with backwash pump (not combinable with built-in fermentation chamber)
- turning basket and dumping trays (each 4-or 6-row)
- high trolleys (16, 18 and 20 shelves)
- extensive accessories, e.g. automatic filling station and sugar turntable for easy filling and sugaring of the products



OPTIONAL: INTEGRATED FERMENTATION CHAMBER

ILLUSTRATION OF TANK & PUMP

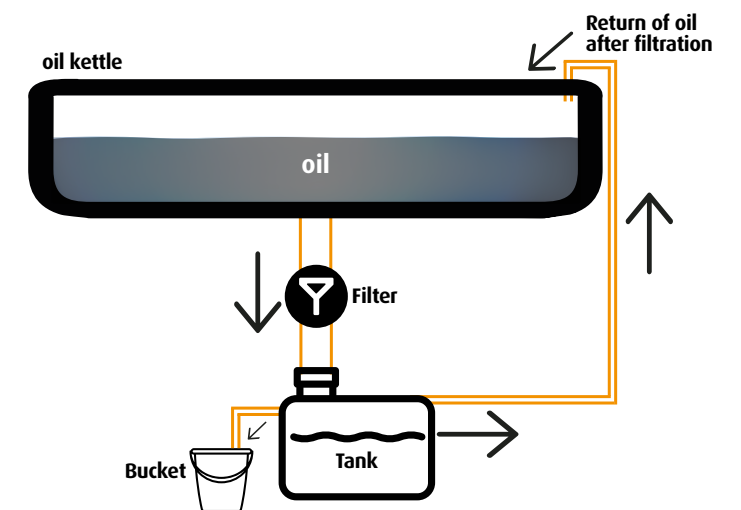

THE USED OIL IS COLLECTED BY THE FILTER SYSTEM IN A TANK AFTER THE END OF WORK AND CAN BE PUMPED BACK INTO THE OIL KETTLE BY THE BACKWASH PUMP OR DRAINED INTO A BUCKET.

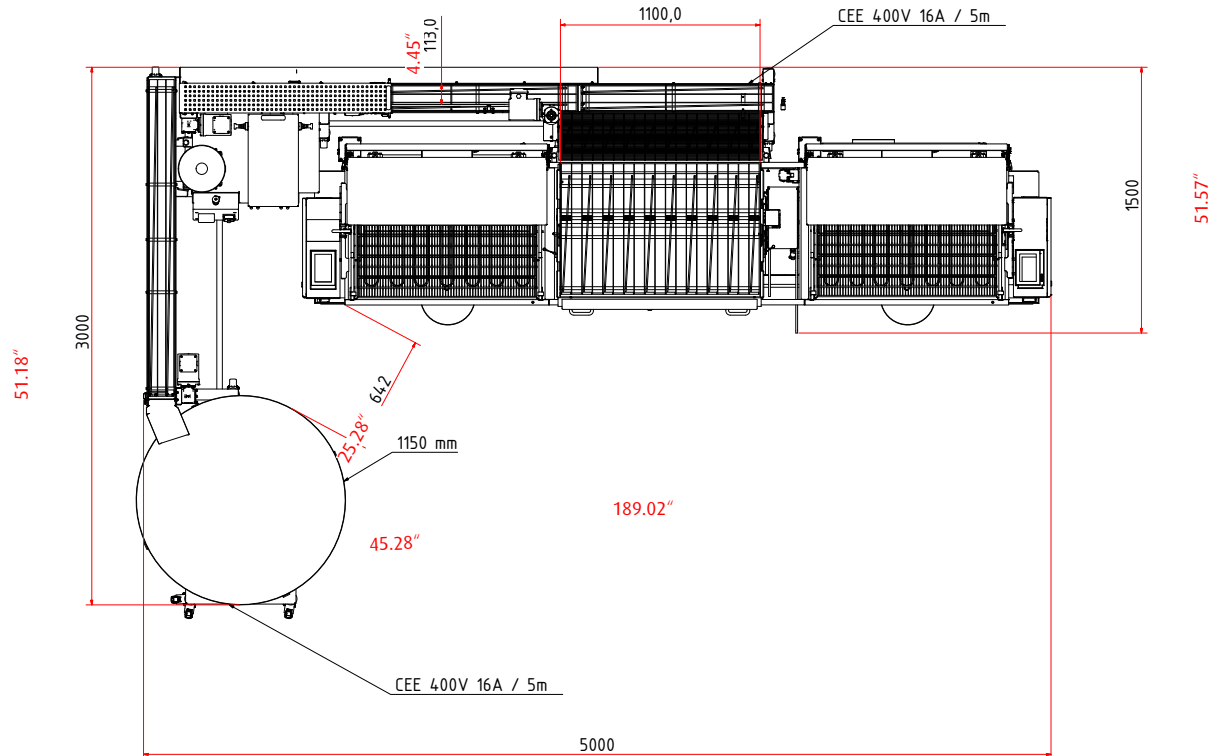

TECHNICAL DETAILS		Size 36	Size 48	Size 60
Length		100.8"	124.8"	148.03"
Width		39.0"	39.0"	39.0"
Weight empty		approx. 551 lb	approx. 595 lb	approx. 639 lb
Voltage	3-ph/1-ph	208-240V/60Hz	208-240V/60Hz	208-240V/60Hz
Max. connected load:				
Heater		2x 6-8 kW	2x 7.5-10 kW	2x 9.0-12 kW
Fermentation chamber		2x 0.8-14 kW	2x 0.8-14 kW	2x 0.8-14 kW
Connection		2x 0.1 kW	2x 0.1 kW	2x 0.1 kW
Lifting motor		2x 9 gal	2x 11 gal	2x 15 gal
Capacity		2x 34 ltr/31 kg	2x 42 ltr/39 kg	2x 49 ltr/46 kg

On this fat baking device you can rely on!

WP LEBENSMITTELTECHNIK RIEHLE GMBH

Heinrich-Rieger-Str. 5 // D-73430 Aalen, Germany // Tel. +49 7361 5580-0 // Fax +49 7361 5580-2281
info@riehle.de // www.riehle.de